

Luxury Lift LLH 950 - Hydraulic Home Elevator

QUALITY • SAFETY • DEPENDABILITY • BEAUTY • ENGINEERING EXCELLENCE



Residential Elevators, Inc. (REI) is pleased to offer the **Luxury Lift LLH 950** hydraulic elevator line with our largest size and payload ever. The **Luxury Lift LLH 950** hydraulic elevator has an industry leading 950lb capacity - **STANDARD!**

Benefits: The **Luxury Lift LLH 950** residential elevators are built using the same design criteria developed over decades and used in the commercial and industrial elevator market. REI's **Luxury Lift LLH 950** gives the lifting capacity normally available only with commercial elevators. Complement the **Luxury Lift LLH 950** with your personal choice of cab appointments and enjoy commercial elevator features at residential elevator prices.

Low maintenance consistent with REI's reputation and demonstrated track record for effective and highly engineered hydraulic elevators with affordable cost and beautiful finish.

- **Factory Direct Savings!**
- Only 96" of clear overhead needed and an 8" recessed pit
- Can accommodate hoistway up to 55-1/2" x 63-1/2"
- Platform size up to 42" x 58-1/2"

Custom Features To Your Order:

REI will custom build many upgrades to your exact specifications including: extra gates, change of cab height, observation glass panels, frame and panel, keyed hall station, custom interior, custom fixtures, power gates, and much more.

STANDARD FEATURES

- Free job site survey by one of our trained representatives
- One (1) year warranty
- 950 lb. capacity
- Auto Lowering Emergency System
- Travel standard up to 50 ft.
- Travel speed of 40 ft. per minute
- 3/8" Heavy Duty Aircraft cables
- Two speed leveling valve
- PLC (Programmable Logic Controls) Controller
- 3/4" sturdy cab walls (7 ply custom cabinet grade material)
- Custom made cab and interior to your specifications
- Aluminum anodized scissor gate or accordion style solid gate
- Standard interior cab color choices: (Pre-finished Maple or Oak and Classic White)
- Solid matching hardwood handrail
- Recessed lighting
- Single integrated car operating panel with built in phone and emergency light
- "Car Here" and "In Use" indicators
- Meets or exceeds all ASME/ANSI A17.1 National Safety Codes for Elevators - Section 5.3 **Private Residence Elevators.**

OPTIONAL SELECTIONS

- Woods other than standard
- Additional gate(s)
- Custom gate(s)
- Oversize cab
- Over height cab up to 8'-0"
- Variety of custom cabs
- Observation glass panel inserts
- 750 lb. capacity (as necessary by Code in certain areas)
- Mirror with hardwood trim
- Halogen downlights
- Keyed hall station
- Remote diagnostics and monitoring
- Auto homing / auto light / auto run
- And much more - Contact your local REI representative for all the details and options



RESIDENTIAL ELEVATORS, INC.

20 Residential Drive, Crawfordville, FL 32327
Ph (850) 926-6022 • Toll Free (800) 832-2004 • Fax (850) 926-5319
www.ResidentialElevators.com
e-mail: sales@ResidentialElevators.com

THE INFORMATION CONTAINED HEREIN IS SOLELY OWNED BY RESIDENTIAL ELEVATORS, INC. ANY REPRODUCTION IN PART OR AS A WHOLE WITHOUT WRITTEN PERMISSION FROM RESIDENTIAL ELEVATORS, INC. IS STRICTLY PROHIBITED.

Luxury Lift LLH 950 - Hydraulic Home Elevator

Standard Hoistway Plans *

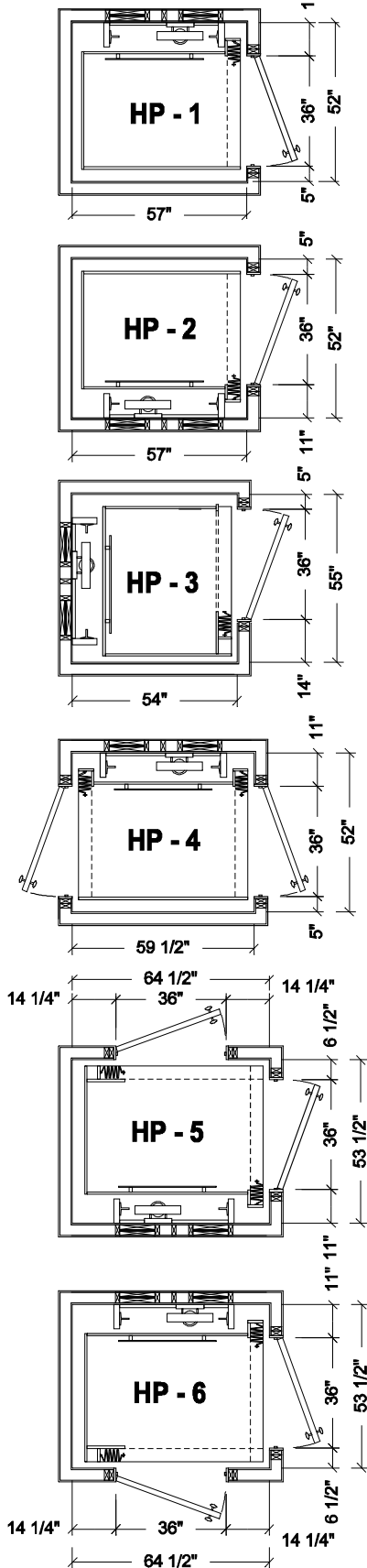

* All dimensions based on Accordion Style Gate

Luxury Lift LLH Hydraulic Contract Specifications

To Specify: The manufacturer shall furnish _____ hydraulic residential elevator(s) (LLH-952, LLH-953, LLH-954, LLH-955) as manufactured by Residential Elevators, Inc. for hoistway plan _____

Design Characteristics: Hydraulic elevator(s) shall have:

Capacity: 950 lb. - standard 750 lb. - optional **Speed:** 40 fpm

Travel: _____ ft. _____ in. (50' - 0" max.) Approx.

Landings Served: _____; with openings at _____ front, _____ rear, _____ right, _____ left

Door Size: (____ w x ____ h) **Door Swing:** Right: _____ Left: _____

Hoistway: (Size: _____ x _____)

Hoistway Pit: 8" Minimum

Std Cab Interiors: Pre-Finished Birch: _____ Pre-Finished Oak: _____ Classic White Laminate: _____

Optional Species: Mahogany: _____ Cherry: _____ Walnut: _____ Alder: _____ Maple: _____

Bamboo: _____ [Note: All wood species available in stained and lacquered finish or unfinished.]

Cab & Hall Stations: Stainless Steel (#4): _____ Bronze (brushed or antique): _____ Black: _____

Hydraulic Power Unit: A power unit especially designed and manufactured for this service shall be furnished. It shall include a constant displacement rotary screw type pump, submersible pump motor, oil reservoir, hydraulic control unit and oil level gauge. The hydraulic control unit shall include a safety check valve, an UP direction valve with high pressure relief including UP leveling and soft stop features, a lowering valve including DOWN leveling and a manual lowering feature (Two-Speed Valve); all encased in a compact unit assembly. The control valves shall be solenoid operated and designed to open and close gradually to give smooth starts and stops. All valves shall be readily accessible for adjustments. The power unit shall be located near the hoistway at the lowest landing, and shall be contained in a metal cabinet.

Controller: The controller components shall be enclosed in a metal cabinet. It shall contain the following components: Power relays and overload device suitable for the size motor and power supply. A microprocessor unit for all logical control and safety circuits. All components to be protected by fused circuits. An emergency, battery UPS operated circuit, shall be incorporated in the control logic to automatically provide emergency lighting and lower the lift in the event of an electric power failure. Batteries to be maintained at full charge by a trickle charge circuit during normal operation.

Guide Rails: Shall be two (2) 8 lb. planed T section with smooth splices, located on one load bearing hoistway wall to accurately guide the cab and piston and shall be secured to that wall by suitable steel brackets and hardware.

Car Frame / Suspension: The steel car frame shall be attached to and suspended by two (2) 3/8" heavy duty aircraft cables. The cables shall be fastened to the pit structure on one end and pass over the U groove sheave to shackles attached to the car frame and safety device. Should one or more cables break or slacken, a broken rope safety mechanism shall apply two cams to wedge against the elevator guide rails and bring the car to a complete stop.

Plunger: The plunger shall be manufactured from accurately ground and polished seamless steel tubing. The bottom of the plunger shall be fitted with a heavy steel disc Stop Ring welded in place and provided with a suitable extended edge to provide a positive stop designed to prevent the plunger from leaving the cylinder in the up direction. The top of the plunger shall be provided with an internally welded steel disc drilled and tapped for fastening a U-groove sheave for 1:2 roping application.

Cylinder: The cylinder shall be machined from steel pipe with a steel flange at the upper end and a heavy steel bulkhead welded in the lower end. The cylinder shall be provided with a suitable steel fitting for connecting the oil line and shall be provided with an air bleeder.

Pipe Rupture Valve: An automatic shut-off valve in the oil supply line at the cylinder inlet will be provided. When there is a drop in no-load operating pressure, or an overspeed in the down direction, the automatic shut-off valve shall be actuated and immediately stop the elevator.

Work By Others:

1. Construction of a suitable, clean, clear, square, plumb (including pit) and legal elevator hoistway consistent with State and Local building codes. (Refer to manufacturer's hoistway plans.)
2. Electrician shall furnish 240 VAC, 30AMP circuit with 10/3 wire with ground to elevator controller.
3. Electrician shall furnish a 120 VAC, 20AMP circuit to elevator controller for the car lighting system.
4. Suitable, hinged, solid core hall doors. Door openings are 3'-0" std. unless otherwise specified.
5. 8" deep recessed pit area.
6. Connection of telephone traveling cable to outside central exchange as required by ASME/ANSI 17.1 code.
7. Special engineered Drawings or plans and any State, County or Local Permits.
8. Proper rail blocking support per REI specifications.
9. GFCI receptacle to be provided in controller area.
10. A 120 VAC switched light to be located in machinery space.

**Standard Hoistway Plans, as drawn,
are recommended size requirements only.
Contact REI for layout assistance if your needs are different.**

RESIDENTIAL ELEVATORS, INC.
www.ResidentialElevators.com - Toll Free (800) 832 - 2004